

Electroniques (Prop. STC Ltd.) Data Sheet

EDINBURGH WAY, HARLOW, ESSEX. Telephone: Harlow 26777 : Telex: 81146

Q - 2/1
ISSUE 9.

GC166 & QP166 MARK VI) 'QOILPAX' by ELECTRONIQUES.

Our new 'QOILPAX' series have been specially developed to meet the demand for high performance tuners for use as complete 'front end' units in communications type receivers. The units possess an unusually high degree of sensitivity (typically 1 μ V for 15dB S/N ratio when followed by a normal IF strip) and selectivity, due to the use of our very high 'Q' 'STABQOILS' (Brit. & For. Patents) throughout all the tuned circuits, and also the inclusion on the chassis of one of our Series 3 De-luxe high selectivity IF Xfrs as the 1st IF Xfrs, having both high & low impedance output, enabling the units to be used as complete convertors if reqd. This IF Xfr also matches correctly into the input of our 1.620 M/cs Xtal filter (See Data Sheets). The high sensitivity RF stage is designed round the high slope frame grid valve type EF183, connected in a Miller compensating circuit, followed by an ECH 81 triode heptode frequency changer, using oscillator circuits giving optimum mixing conductance on each waveband without any 'pulling', each osc. coil not in use being shorted out. Two models are available, both designed for an IF output of 1620 K/cs. Second channel interference is exceptionally low due to the choice of this IF freq., together with the very high 'Q' of the two input circuits.

'QOILPAX' units are completely wired, tested & aligned & are supplied complete with the two valves, black valve screens, tuning condenser, 1st IF Xfr, all resistors & condensers, decoupling, etc. & all connecting points are terminated to coloured nylon lead-through insulators, clearly marked. Provision is made for a variable RF gain control to be added if reqd, likewise an antenna trimmer control. Chassis size is 6" x 6" x 2" deep plus 3" above chassis, & the layout is particularly suitable for use with the Eddystone dial type 898, or our 2-speed slow motion dial SMD2 (See data sheets) or any good epicyclic drive. Firm fixing is provided at two alternative points at the back or sides of the units, together with two further fixings, one each side near the front. These fixing brackets can also be reversed to allow various height levels to be obtained from the main Rx chassis.

BANDSPREAD HAMBANDS Model QP166 has been specially designed to give maximum performance and complete bandspread of the six popular hambands 160 to 10m. Each hamband is bandspread over approx. 170° rotation of the tuning condenser which is a special double-spaced silver plated type without stops, so that the dial system can be set up with the HF ends of each band either on the LH side or RH side of the dial. To enable accurate calibration to be obtained adjustable padders are included in the osc. section for the 4 highest freq. ranges, as well as adjust. cores & trimmers. Aerial input impedance is 75 ohms (LZ), & the input circuits are so arranged that either single-ended (long wire) or dipole connections are possible. A 'High Q' IF whistle filter circuit is also included. In all stages ALL COILS NOT IN USE ARE SHORTED OUT.

GENERAL COVERAGE Model GC166 also 6 wavebands (M/W & 5 S/W bands, including all 6 hambands) tuned by a special 265pF 3-gang SLF law condenser, & each waveband is so designed that the 80, 40, 20, 15 & 10m bands are at the HF end of each S/W range. The aerial input impedance is 600 ohms to suit random length aerials, & the IF whistle filter circuit is similar to the QP166, and all coils not in use are shorted out.

Gram switching is not provided with any of these units, but a spare 2-pole 6-way wafer can be provided on the switch in front of the chassis for switching band indicator lights or other aux. circuits at an extra cost of 4/6d.

P. T. O.

High-grade components for amateur communications



PRICE: Both models £12.12s. 0d each complete with valves & supplied in polythene bag, with full instructions, circuit diagram and 8-page reprint of the G3HTA Communications Rx design, & 2 special trimming tools.

'QOILPAX' by ELECTRONIQUES.

BANDSPREAD HAMBANDS MODEL QP166.

MODEL QP166 for 1.620 M/cs IF with high gain RF stage. Antenna input 75 ohms dipole, or single ended, with IF whistle filter included. Each hamband is bandspread over approx. 170 rotation of the special 6/20pF silver plated double spaced tuning condenser. Supplied absolutely complete, with EF183 RF valve & ECH81 F/C valve, all resistors & condensers, padders, etc. plus high selectivity 1st IF Xfr, having both high & low impedance output. Completely tested & aligned against crystal calibrators. Chassis size 6" x 6" x 2" deep plus 3" above chassis. Suitable for use with Eddystone dial type 898, or our 2-speed slow motion dial SMD2 (See data sheets) or any good epicyclic drive.

<u>Range.</u>	<u>Hamband.</u>	<u>Frequency coverage.</u>
1	10m.	28.0 M/cs to 30.0 M/cs.
2	15m.	21.0 " " 21.5 "
3	20m.	14.0 " " 14.4 "
4	40m.	7.0 " " 7.3 "
5	80m.	3.5 " " 4.0 "
6	160m.	1.8 " " 2.0 "

GENERAL COVERAGE BROADCAST BANDS, MODEL GC166.

MODEL GC166 for 1.620 M/cs IF with high gain RF stage, 600 ohm impedance aerial input, particularly suitable for random length aerials, & IF whistle filter. Complete with valves, types EF183 (RF) and ECH81 (F/C), 3-gang 265pF SLF tuning condenser & all resistors & condensers, AGC feeds, HT decoupling, etc., plus high selectivity 1st IF Xfr with both high & low impedance output. Chassis size 6" x 6" x 2" deep, plus 3" above chassis. Suitable for use with Eddystone dial, type 898 or our 2-speed slow motion dial SMD2 (See data sheets) or any good epicyclic drive. 4 adjustable fixing feet. Completely aligned and tested.

<u>Range.</u>	<u>Waveband (m)</u>	<u>Frequency coverage.</u>	<u>(Hambands covered)</u>
M.W.	545 - 200	550 K/cs to 1.5 M/cs.	-
S.W.1.	177 - 73.0	1.7 M/cs " 4.1 "	160 & 80 m.
S.W.2.	75.0 - 37.6	4.0 " " 8.0 "	40 m.
S.W.3.	40.0 - 20.0	7.5 " " 15.0 "	20 m.
S.W.4.	21.4 - 13.7	14.0 " " 22.0 "	15 m.
S.W.5.	15.0 - 10.0	20.0 " " 30.0 "	10 m.

Power requirements for both models, H. T. + 250 volts at 20mA, & 150 volts stabilised for oscillator. Heaters 6.3 volts at .6 amps.

SPECIAL NOTE: For maximum performance and frequency stability a stabilised 150 volt HT supply MUST be used for the oscillator section. Also the back valve screens MUST be used.

P. T. O.

In both models the lowest frequency band is at the max. clockwise position of the band-switch.

Gram switching is not provided with any of these units, as we feel the correct way to select alternative inputs is to use a proper multiway wafer switch so that other inputs, such as F.M., Tape or Gram, as well as A.M., C.W. or S.S.B., can be fed into the main audio channel.

'QOILPAX' OPERATING NOTES, MODELS QP166 & GC166.

Our QP166 hambands bandspread 'QOILPAX' & GC166 general coverage 'QOILPAX' have been specially designed for the enthusiast wishing to build a communications type receiver. All the "headaches" have been taken care of as far as the 'front end' is concerned, and the units will give a very high performance indeed. High sensitivity is obtained due to the use of the high slope frame grid valve Type EF183, connected in a Miller compensating circuit, followed by a triode heptode frequency changer Type ECH81. A special oscillator circuit arrangement is used to obtain optimum oscillator conversion conductance on all bands without 'pulling', and all oscillator coils not in use are shorted out. In the QP166 model each of the 6 bands 160m - 10m is completely bandspread over approx. 170° rotation of the tuning condenser, the 160m band being in the max. clockwise position of the bandswitch. The general coverage model covers 1.7 M/cs to 30 M/cs in 5 slightly overlapping bands, together with complete coverage of the M/W band. There is only a small break in coverage between 1.5 M/cs & 1.7 M/cs to allow for the IF frequency. Again, the lowest frequency band (M/W) is at the max. clockwise position of the bandswitch and in both models all coils not in use in the RF & mixer and osc. stages are shorted out.

The units also possess in themselves an unusually high degree of selectivity (resulting in exceptionally low second channel interference), due to the use throughout of our very high 'Q' 'STABQOILS' Reg. Trade Mark (Brit. & For. Patents), all of which have temperature-compensated adjustable capacity trimmers incorporated, as well as adjustable cores, also the inclusion on the chassis of one of our 1.6 M/cs Series 3 de-luxe high selectivity IF Xfrs as the 1st IF Xfr. These Xfrs have both high & low impedance output, enabling these units to be used as complete convertors, if reqd. The units are supplied with both valves & screening cans, and are completely wired with all resistors & condensers, including all decoupling networks, AGC feeds etc. & all leads are terminated to coloured nylon lead-through insulators suitably marked.

The HT line should be between 200 & 250v at 20mA, & the oscillator stage MUST be fed with a STABILISED 150v supply. (Voltage regulators types 150C4, OA2 or VR150/30 are suitable). The heaters require 6.3v at .6A. The cathode of the RF valve is brought out to a separate leadthrough & decoupled, to enable an RF gain control to be used, if reqd. This RF gain control should consist of a 10 K/ohm linear pot, with one side connected to negative or chassis, the slider taken to the leadthrough point via a 200 ohm resistor, & the top end of the pot connected in series with a 25 K/ohm 1-watt resistor, to the HT line. If this is not reqd, then connect the 'RF GAIN' leadthrough to E, through a 200 ohm $\frac{1}{2}$ -watt resistor. IT IS IMPORTANT THAT THE MINIMUM CATHODE VOLTAGE ON THE EF183 IS NEVER LESS THAN 2.5 VOLTS.

P. T. O.

Each unit is very thoroughly tested & accurately aligned before despatch, to an IF of 1620 K/cs. THEREFORE, IT IS VERY IMPORTANT NOT TO TOUCH THE TRIMMERS until everything else in the Rx is functioning perfectly. Due to the large inductances & small capacities employed in the tuned circuits of the QP166 model, ONLY MINUTE ADJUSTMENT OF THE OSCILLATOR trimmers or padders will be needed if the band edges do not exactly suit your requirements. If the band edges do need resetting, this should only be done in conjunction with the use of a first-class signal generator having crystal calibration facilities. A completely insulated screwdriver blade trimming tool is essential for these adjustments, such as our TT3. However, regarding the RF stage, it is recommended that each trimmer in the RF stage be re-peaked at midband to suit the particular antenna in use. (2 special trimming tools are included with each unit for such adjustments.)

Alternatively, if a front panel antenna trimmer control is desired, then a small high grade variable tuning condenser can be fitted in parallel with the RF stage tuning condenser, which is the first section of the 3-gang nearest to the front panel. For the QP166, $3/15p^F$ is suitable, with $5/50p^F$ for the GC166 model. If such a control is fitted, then it will be necessary to reset the small trimmers on each of the RF coils (which are in the compartment nearest to the front panel) to offset the additional capacity introduced by the antenna trimmer.

To realign the RF stage coils, proceed as follows, preferably using a sig. gen. as the signal source:- Set front panel trimmer to approx. half value & main tun. condenser to midband & bandswitch to 160m or M/W. Feed in signal from generator & retrim RF trim. condenser to top of the appropriate coil to max. signal as read by an S meter or VVM connected to the AGC line. Repeat for each band. Any reflected loading by the antenna can then be balanced by the front panel control. If 75 ohm twin feeder is used the connections will be to A & A1, if coax feed or long wire antennae are used, then strap A1 to E & connect centre wire of coax to A, & the braiding to E. Likewise, connect a long wire feed to A. For optimum results, naturally a resonant aerial system for each band is ideal, or an aerial tuning unit can be added, but due to the inherent high sensitivity of these units extremely good results can be obtained with quite short aerials.

An adjust. IF whistle filter is included in these units, & has been set to the IF freq. However, this may be adjusted to any other near freq. to suit any local interference problems. Output from the IF Xfr on the 'QOILPAX' chassis is taken from the single lead-through insulator at the back of the unit, straight to the grid of the following 1st IF amp stage. AGC is applied to the 1st IF stage via the end leadthrough insulator on the side of the unit marked IF AGC. A resistor of between 100 K/ohm & 500 K/ohm from the main Rx AGC line should be connected to this point & decoupled with a condenser of between .01 & .1uF, depending upon the time constants reqd for the AGC. If low impedance output is reqd, such as would be needed to feed into the antenna input of a Rx or if the IF chain is some distance away from the tuner or for feeding into our 1.620 M/cs Xtal filter (See Data sheets) then the green lead connected to the IF Xfr underneath the unit must be moved from the outside targe of the IFXfr to the middle tag. The leadthrough insulator marked IF AGC is then connected to the chassis earth. Retrimming of the 1st IF Xfr cores for max. signal output is advised to correct for any external stray C's of the following input stage.

P. T. O.

Both the Eddystone type 898 dial & our Type SMD2 is suitable (See data sheets). A flexible coupler MUST be used between the gang spindle & the dial system. 4 fixing feed are provided round the chassis, & the back pair can be moved to the sides to assist in mounting the unit into the main Rx chassis. They can also be reversed for different height levels to be obtained between the 'QOILPAX' & main Rx chassis. The hole cut-out should be 6-1/16" sq. + extra cut-out to clear the flywheel if Eddystone dial is used.

IMPORTANT. Due to the use of temp. compensating capacitor it is important to avoid placing any heat radiating comp. near the rear osc. section of the 'QOILPAX'. Likewise, if ventilation holes are provided in the cabinet be sure that erratic air-draughts do not pass over or through the osc. compartment. The black valve screens supplied MUST be used.

With suitable follow-on circuits, performance equal to expensive commercials Rxs can be expected with sensitivities of better than 1uV for 15dB S/N ratio.

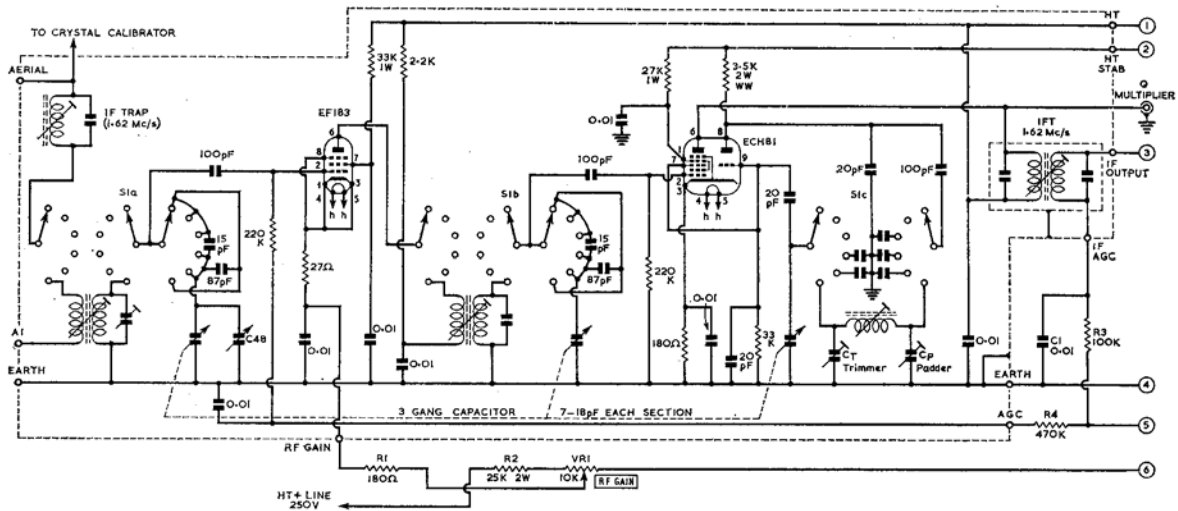

The front-end of the receiver (Electroniques type QP166). The bandswitch is shown in the 160 metre position. Only the coils and trimmers for 10 metres are shown; the others occupy corresponding positions on the other bandswitch contacts. The oscillator switch section SIC is fitted with shorting contacts.

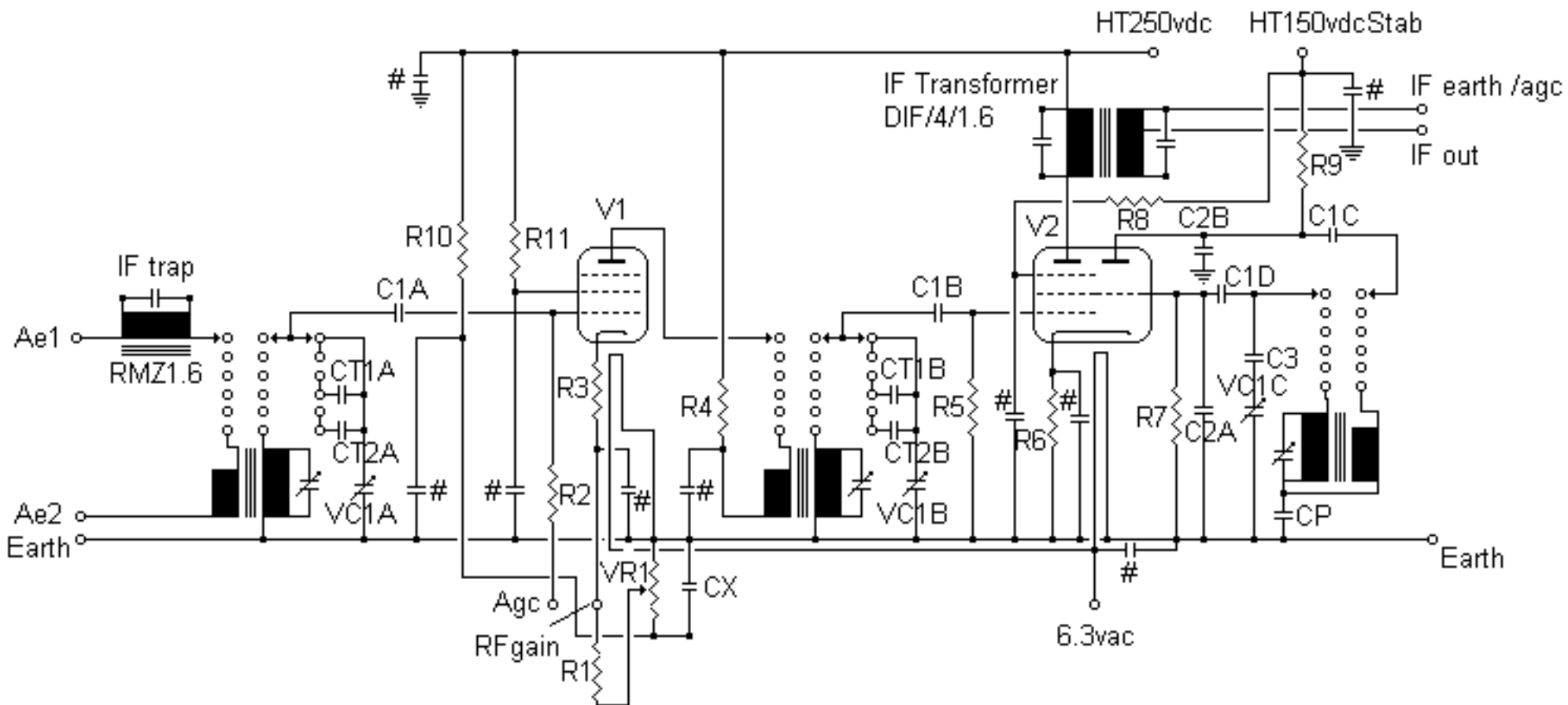

GC166 ELECTRONICS GENERAL COVERAGE 'QOILPAX'

10,000pf 300VDC
 C1A,B,C,D 100PF 160VDC
 C2A,B 20PF 300VDC
 C3 430PF 160VDC
 CT1A,B 350pf 160vdc SW2+3
 CT2A,B 100pf 160vdc SW4+5
 VC1A,B,C 10-270 PF 3GANG

CP Mw 430pf
 CPSW1 1000pf
 CPSW2 650pf
 CPSW3 1100pf
 CPSW4 270pf
 CPSW5 270pf
 @CX 10,000pf 300vdc

@R1 200 Ohms 0.5Watt
 R2 220 K 0.5Watt
 R3 27 ohms 0.5Watt
 R4 2.2K 0.5Watt
 R5 220 K 0.5Watt
 R6 180 ohms 0.5Watt
 R7 33K 0.5Watt

R8 27K 1Watt
 R9 4.0K 4 Watt w/w
 @R10 25K 1 Watt
 R11 33k 1 Watt
 @VR1 10K linear
 Valves V1 EF183
 V2 ECH81

Items marked @ are fitted externally to the tuner for RF gain control